



# 380 SERIES

## EXPLOSION PROOF LIGHTING



4 Lamp 4 Ft. Fixture



3 Lamp 4 Ft. Fixture



2 Lamp 4 Ft. Fixture



2 Lamp 2 Ft. Fixture

PATENT PENDING

### DESCRIPTION

The 380 Series is a must for any Explosive Atmosphere Location! (see listings below) This product has five different hub entries at each end enabling the installer to wire the fixture for more desirable angles than a single entry. The center located ballast allows for a more balanced fixture for ease of installation and weight distribution. The 380 Series is available in 2' & 4' lengths for 2, 3, & 4 lamp combinations in T5, T5HO, T8, T8HO, T12 & T12HO. Lamps included.

### SPECIFICATIONS

#### LISTINGS:

UL 844 listed and labeled - Hazardous Locations:  
 Class I, Division 1, Groups C and D; Class I, Division 2, Groups A, B, C and D  
 Class II, Division 1 and 2, Groups E, F and G; Class III.  
 UL 1598A listed and labeled - marine type lighting fixture. Outside Type (salt water)  
 UL 1598A testing equivalent to NEMA 4X requirements for hose-down and corrosion resistance.  
 UL listed 1598  
 UL listed and labeled for use inside paint spray booths and rooms.  
 Also meets requirements for National Fire Protection Association Standard 33  
 and National Electrical Code Article 516.  
 UL C approved and labeled Class I, Division 1, Group C and D  
 Class I, Division 2, Groups A, B, C and D  
 Class II, Division 1 and 2, Groups E, F and G; Class III.  
 NEMA 3, 4X, 7CD, 9EFG.  
 Simultaneous presence Class I and Class II  
 Suitable for use inside paint spray booths.  
 Class I, Zone 1, Group II A  
 Class I, Zone 1, Group II B



#### HOUSING:

Factory Sealed, Cast Natural Aluminum (U.S. Foundry) that is lightweight  
 Ballast mounted in the center for better balance and low profile.  
 (5) 1/2" NPT Hubs located at 0°, 45° and 90° angles.

#### REFLECTOR:

One piece painted aluminum reflector with 93% reflective white finish

#### LENS:

3/16" Clear tempered glass tubes

#### ELECTRICAL:

120-277 Volt (T5, T5HO & T8 only)  
 120 Volts (T8HO, T12, & T12HO)  
 220 Volts 50 Hz (T12)  
 277 Volts (T8HO, T12, & T12HO)  
 347 Volts (T8 & 4 Ft. T12 only)

#### APPLICATIONS:

Hazardous locations, Paint spray booth, Marine/shipboard, Chemical Manufacturers  
 Oil Drilling Rigs, Gas Processing Plants, Refineries

#### OPTIONS:

All Options Ordered Separately - See next page  
 Optional Polycarbonate Shield and Stainless Steel Guard.  
 EM: Emergency Battery Backup Ballast  
 120 or 277V MUST SPECIFY  
 HB: 93% Reflective specular reflector insert

TASK ①

PAINTBOOTH ②

VAPOR DUST ③

VAPOR ④

WET DAMP ⑤

MARINE ⑥

EXPLOSION PROOF ⑦

HID ⑧

INSPECTION ⑨

PORTABLE LIGHTING ⑩

MOUNTING ⑪

PHOTOMETRY ⑫

LAMPS BALLASTS ⑬

INFO ⑭

CUSTOM ⑮

ASK THE EXPERT ⑯



# 380 SERIES

## EXPLOSION PROOF LIGHTING

### PART NUMBERS

- ① TASK
- ② PAINTBOOTH
- ③ VAPOR DUST
- ④ VAPOR
- ⑤ WET DAMP
- ⑥ MARINE
- ⑦ EXPLOSION PROOF
- ⑧ HID
- ⑨ INSPECTION
- ⑩ PORTABLE LIGHTING
- ⑪ MOUNTING
- ⑫ PHOTOMETRY
- ⑬ LAMPS BALLASTS
- ⑭ INFO
- ⑮ CUSTOM
- ⑯ ASK THE EXPERT

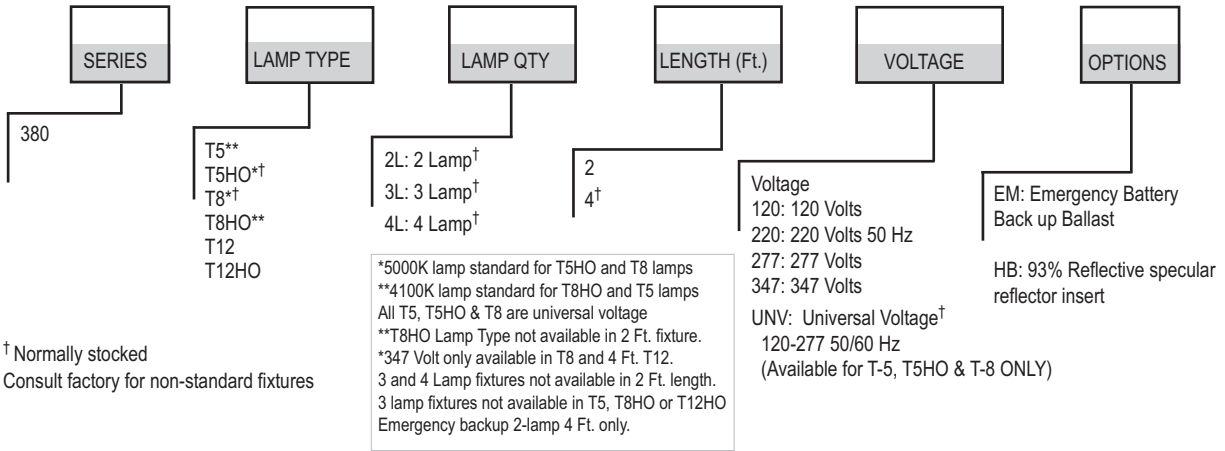

Operating Temperature Codes Based on 40° C Ambient					
FIXTURES	Class I, DIV 1 Groups C & D	Class I, DIV 2 Groups A, B, C, D	Class II, DIV 1 Groups E, F, G	Class III	Simultaneous Presence Class I & II
380-T12HO-2L-4-120	T5= 100° C	T4= 135° C	T4= 135° C	T4= 135° C	T4= 135° C
380-T12HO-2L-4-277	T5= 100° C	T4= 135° C	T4= 135° C	T4= 135° C	T4= 135° C
380-T12HO-4L-4-120	T5= 100° C	T4= 135° C	T4= 135° C	T4= 135° C	T4= 135° C
380-T12HO-4L-4-277	T5= 100° C	T4= 135° C	T4= 135° C	T4= 135° C	T4= 135° C
All Other 380 fixtures	T6= 85° C	T4= 135° C	T4= 135° C	T4= 135° C	T4= 135° C

LAMP WATTAGES			
2 Ft.	WTS	4 Ft.	WTS
T5	14 Watt	T5	28 Watt
T5HO	24 Watt	T5HO	54 Watt
T8	17 Watt	T8	32 Watt
T8HO	NA	T8HO	44 Watt
T12	25 Watt	T12	34 Watt
T12HO	35 Watt	T12HO	60 Watt

### WEIGHTS

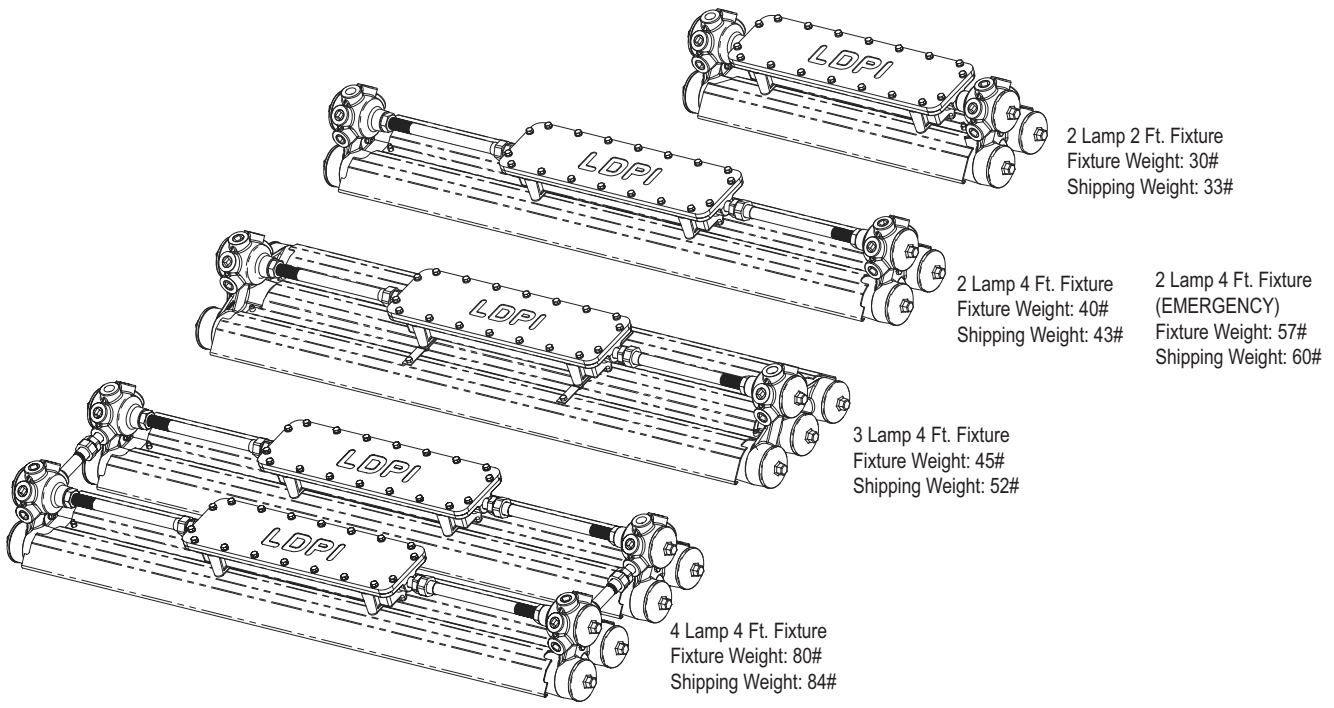



# 380 SERIES

## EXPLOSION PROOF LIGHTING

### OPTIONS



STAINLESS STEEL GUARDS

Description	Catalog Number
2-Lamp 2-Ft. Fixtures	4466
2-Lamp 4-Ft. Fixtures	4211
3-Lamp 4-Ft. Fixtures	4557
4-Lamp 4-Ft. Fixtures	(2) 4211



POLYCARBONATE SHIELDS (+/- 1/16" thickness)

Description	Catalog Number
2-Lamp 2-Ft. Fixtures	4464
2-Lamp 4-Ft. Fixtures	4209
3-Lamp 4-Ft. Fixtures	4497
4-Lamp 4-Ft. Fixtures	(2) 4209

- TASK ①
- PAINTBOOTH ②
- VAPOR DUST ③
- VAPOR ④
- WET DAMP ⑤
- MARINE ⑥
- EXPLOSION PROOF ⑦
- HID ⑧
- INSPECTION ⑨
- PORTABLE LIGHTING ⑩
- MOUNTING ⑪
- PHOTOMETRY ⑫
- LAMPS BALLASTS ⑬
- INFO ⑭
- CUSTOM ⑮
- ASK THE EXPERT ⑯

### MOUNTING OPTIONS



Wall/Ceiling Mount Kit  
 P/N 4401 (For 2 or 3 Lamp)  
 P/N 4400 (For 4 Lamp, not shown)  
 (P/N 4400 must be factory installed)



Drop Mount Kit  
 2 or 3 Lamp P/N 4405  
 4 Lamp P/N 4403

### EMERGENCY BATTERY BACK-UP BALLAST

UL 844, 924, 1598A, 1598

Listed and labeled for Hazardous locations

Class I Div. 1, Groups C & D, Class I Div. 2, Groups C & D

Class II Div. 1 & 2, Groups E, F & G.

Simultaneous presence of Class I & II

Class III, Class I, Zone 1, Groups IIA & IIB

Emergency lighting equipment for hazardous locations.

Nonrecessed marine luminaire, outside type (salt water).

Lumen output varies per lamp selection.

Equivalent to NEMA 4X requirements for hose-down & corrosion resistance.

Listed and labeled for use inside paint spray booths and rooms.

Meets requirements for NFPA 33 and NEC Article 516.

NEMA 3, 4X 7CD, 9EFG.

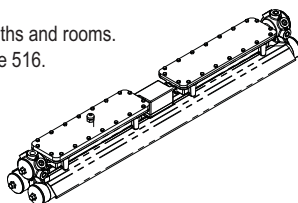

#### FEATURES OF EMERGENCY BACK-UP BALLAST

Only available as 4 Ft. 2 lamp fixture

Vented battery compartment

Explosion proof test switch and charging indicator light

Minimum starting temperature 0° C (32° F)

Maintenance free emergency ballast/battery pack/charger

575 Lumen operation

3 year warranty

#### OPERATION

Operates normally on 120V, 277V, 60 Hz or 220V 50 Hz

When power fails the fixture automatically switches to emergency mode. In emergency mode one lamp will provide safe egress lighting for at least 90 minutes.

The fixture switches to charging mode and resumes normal lighting once AC power is restored.



UL 595, 844, 924, 1598



# 380 SERIES

EXPLOSION PROOF LIGHTING

## DIMENSIONS

- ① TASK
- ② PAINTBOOTH
- ③ VAPOR DUST
- ④ VAPOR
- ⑤ WET DAMP
- ⑥ MARINE
- ⑦ EXPLOSION PROOF**
- ⑧ HID
- ⑨ INSPECTION
- ⑩ PORTABLE LIGHTING
- ⑪ MOUNTING
- ⑫ PHOTOMETRY
- ⑬ LAMPS BALLASTS
- ⑭ INFO
- ⑮ CUSTOM
- ⑯ ASK THE EXPERT

2L 2FT. Dimensions

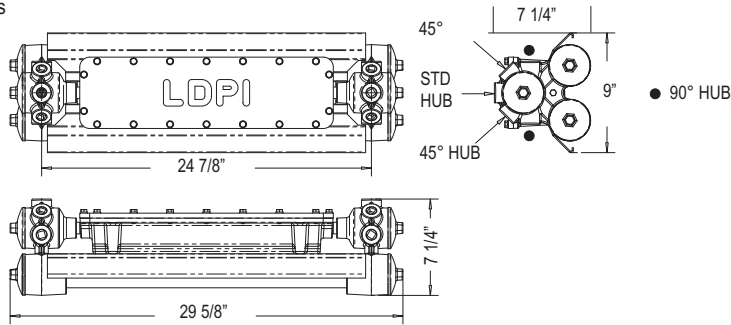

2L 4FT. Dimensions

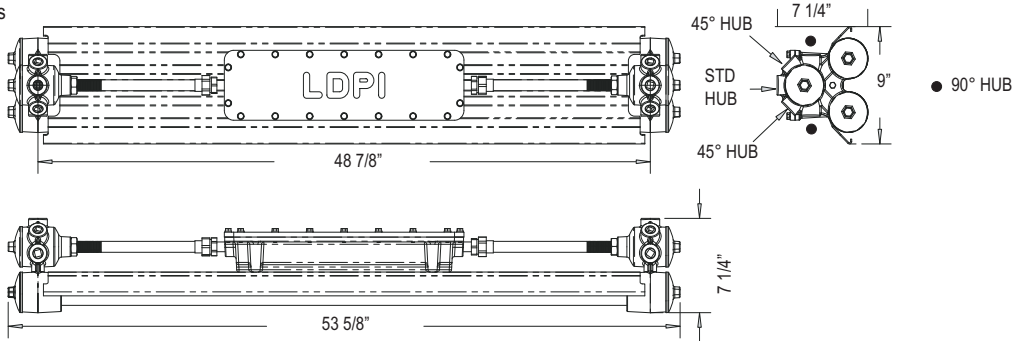

3L 4FT. Dimensions

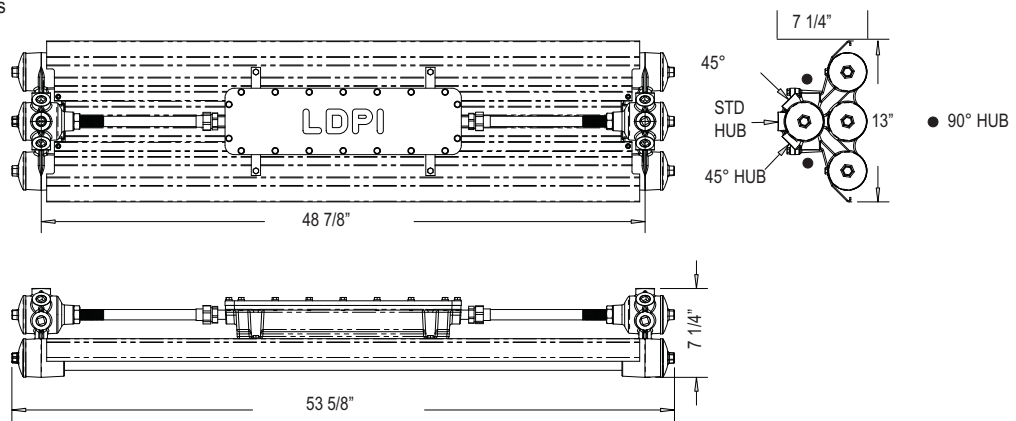

4L 4FT. Dimensions

