

Item Number	Model Number	Construction Code	Actual Size (Inches) H x W x D	Rated Air Flow (CFM)	Initial Resistance (In. W.G.)	Efficiency	Media Area (Square Feet)
2592199	MC-501-XL	H2424B00-0AG 000 040	24 x 24 x 11-1/2	1050	1.20	99.999% @ 0.3 Micron	185
2594496	MC-501A-XL	H2323B33-0AG 000 040	23-3/8 x 23-3/8 x 11-1/2	1000	1.20	99.999% @ 0.3 Micron	173
	MC-500-XL	H1224B00-0AG 000 040	12 x 24 x 11-1/2	525	1.20	99.999% @ 0.3 Micron	88
	MC-500A-XL	H1123B33-0AG 000 040	11-3/8 x 23-3/8 x 11-1/2	500	1.20	99.999% @ 0.3 Micron	79
	MC-500R-XL	H2412B00-0AG 000 040	24 x 12 x 11-1/2	525	1.20	99.999% @ 0.3 Micron	88
	MC-500AR-XL	H2311B33-0AG 000 040	23-3/8 x 11-3/8 x 11-1/2	500	1.20	99.999% @ 0.3 Micron	79
	MC-241-XL	H2424A00-0AG 000 040	24 x 24 x 5-7/8	550	1.20	99.999% @ 0.3 Micron	97
	MC-241A-XL	H2323A33-0AG 000 040	23-3/8 x 23-3/8 x 5-7/8	520	1.20	99.999% @ 0.3 Micron	91
	MC-1202-XL	H1224A00-0AG 000 040	12 x 24 x 5-7/8	275	1.20	99.999% @ 0.3 Micron	45
	MC-1202A-XL	H1123A33-0AG 000 040	11-3/8 x 23-3/8 x 5-7/8	260	1.20	99.999% @ 0.3 Micron	42
	MC-1212-XL	H2412A00-0AG 000 040	24 x 12 x 5-7/8	275	1.20	99.999% @ 0.3 Micron	45
	MC-1212A-XL	H2311A33-0AG 000 040	23-3/8 x 11-3/8 x 5-7/8	260	1.20	99.999% @ 0.3 Micron	42

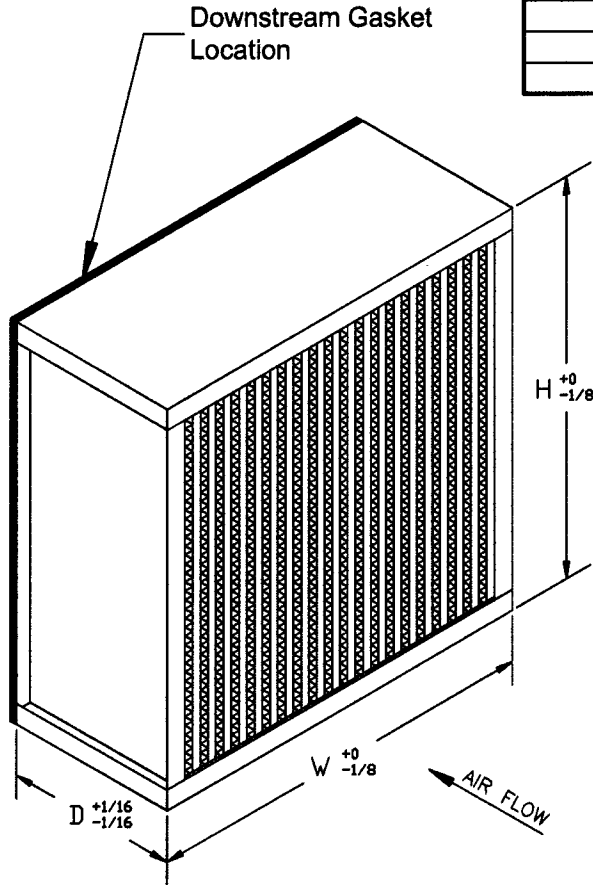

Construction	Code	Description
Standard and Certification	0	HEPA-IEST-RP-CC001.3 per MIL Std. 282
Frame Material	A	16 GA Corrosion Resistant Steel
Frame Style	G	Metal C-Style
Gasket	0	SCE 43 Neoprene 1/4" x 3/4" (180 deg. F), Dovetail Joints
Gasket Location	0	Downstream
Sealant	0	Urethane (180 deg. F)
Hardware	0	None
Acceptance Level	4	99.999% on 0.3 Micron Scanned (Leak Tested)
Separators	0	Aluminum Separators, Standard Capacity

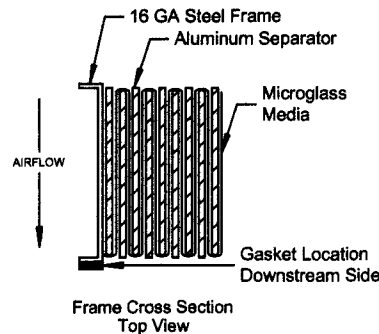

NOTES

- Media: Micro-Glass Fiber / Acrylic Resin Binder
- Rated Velocity
11-1/2" Depth - 250 FPM
5-7/8" Depth - 125 FPM
- See Drawings MKT-B-00354 & MKT-B-00355 For Resistance Curves
- Recommended Final Resistance: 2.4" W.G. @ Rated Flow (Twice Initial Resistance)
- Class 1 Filter Per U.L Standard 900
- Maximum Operating Temperature: 180 Deg. F
- Standard Gasket Location Downstream, Construction Code 0AG 000 040
- Optional Gasket Locations (Do NOT Use Item Numbers Shown Above)
-U: Upstream Sides (Ex. MC-501-XL-U), Construction Code 0AG 110 040
-UD: Both Sides (Ex. MC-501-XL-UD), Construction Code 0AG 130 040
No Gasket (Ex. MC-501-XL, No Gasket), Construction Code 0AG 750 040

AIRGUARD ONE SOURCE FOR AIR FILTRATION PRODUCTS
P.O. Box 32578
Louisville, KY 40232
P: 502-969-2304
F: 502-969-2759

CONTACT FACTORY TO VERIFY REVISION LEVEL

TOLERANCES UNLESS OTHERWISE SPECIFIED

FRACTIONAL	-
DECIMAL	-
ANGLES	-

ALL DIMENSIONS IN INCHES

DRAWING NAME MICROGUARD 99 (C STYLE BOX - 99.999%)

APPROVED BY *H. O...* **SPECIFICATION NO.** MKT-B-00356 **PAGE** 1 OF 1

SCALE NONE **DWG. SIZE** A **REVISION** B **REVISION DATE** 10-02-03

CONFIDENTIAL - DO NOT COPY. THIS MATERIAL IS TRADE SECRET AND PROPRIETARY BEING EXCLUSIVELY OWNED BY AIRGUARD. THE EXPRESSION OF THE INFORMATION CONTAINED HEREIN IS PROTECTED UNDER FEDERAL COPYRIGHT LAWS AND ALL COPYING IS PROHIBITED AND MAY BE SUBJECT TO CRIMINAL PENALTIES.