

Item Number	Model Number	Construction Code	Actual Size (Inches) H x W x D	Rated Air Flow (CFM)	Initial Resistance (In. W.G.)	Efficiency	Media Area (Square Feet)
2950056	MDL-501	M2424B00-000 000 000	24 x 24 x 11-1/2	2000	1.00	95% @ 0.3 Micron	202
2590647	MDL-501A	M2323B33-000 000 000	23-3/8 x 23-3/8 x 11-1/2	1900	1.00	95% @ 0.3 Micron	189
2950475	MDL-500	M1224B00-000 000 000	12 x 24 x 11-1/2	1000	1.00	95% @ 0.3 Micron	94
2950454	MDL-500A	M1123B33-000 000 000	11-3/8 x 23-3/8 x 11-1/2	950	1.00	95% @ 0.3 Micron	85
2953012	MDL-500R	M2412B00-000 000 000	24 x 12 x 11-1/2	1000	1.00	95% @ 0.3 Micron	94
2951591	MDL-500AR	M2311B33-000 000 000	23-3/8 x 11-3/8 x 11-1/2	950	1.00	95% @ 0.3 Micron	85
2950866	MDL-241	M2424A00-000 000 000	24 x 24 x 5-7/8	1000	1.00	95% @ 0.3 Micron	105
2951099	MDL-241A	M2323A33-000 000 000	23-3/8 x 23-3/8 x 5-7/8	950	1.00	95% @ 0.3 Micron	99
2950663	MDL-1202	M1224A00-000 000 000	12 x 24 x 5-7/8	500	1.00	95% @ 0.3 Micron	49
	MDL-1202A	M1123A33-000 000 000	11-3/8 x 23-3/8 x 5-7/8	475	1.00	95% @ 0.3 Micron	44
2955918	MDL-1212	M2412A00-000 000 000	24 x 12 x 5-7/8	500	1.00	95% @ 0.3 Micron	49
2954489	MDL-1212A	M2311A33-000 000 000	23-3/8 x 11-3/8 x 5-7/8	475	1.00	95% @ 0.3 Micron	44

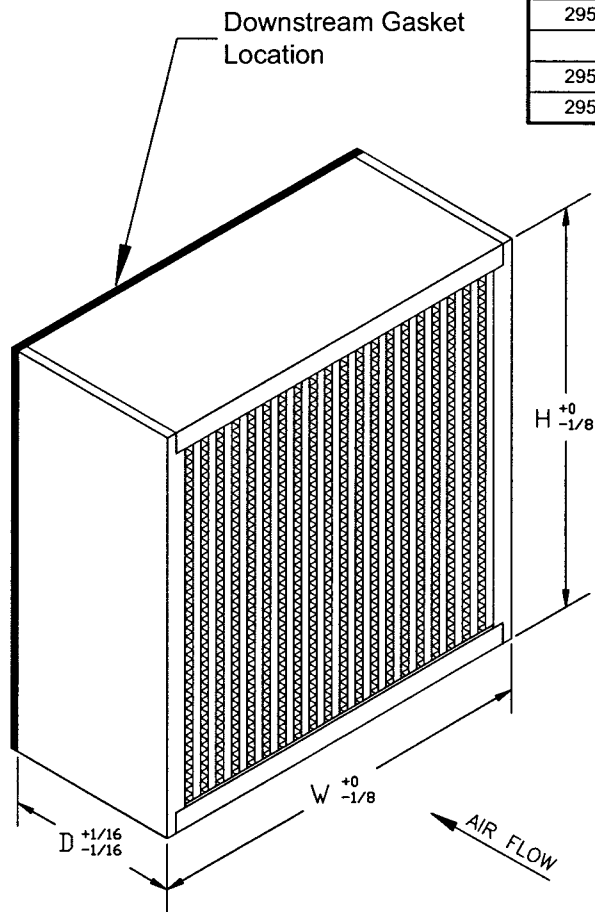

Construction	Code	Description
Standard and Certification	0	HEPA-TEST-RP-CC001.3 per MIL-STD 282
Frame Material	0	3/4" Particle Board (U.L. Class 2)
Frame Style	0	4 Piece Box
Gasket	0	Urethane 1/4" x 3/4" (180 deg. F), Dovetail Joints
Gasket Location	0	Downstream
Sealant	0	Urethane (180 deg. F)
Hardware	0	None
Acceptance Level	0	95% on 0.3 Micron
Separators	0	Aluminum Separators, Standard Capacity

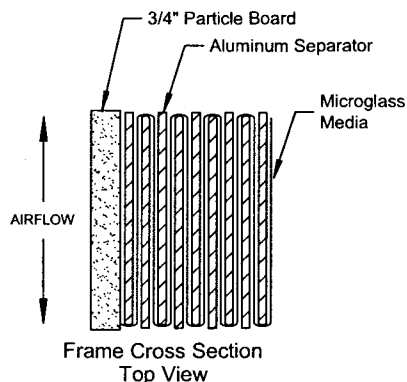

NOTES

- Media: Micro-Glass Fiber / Acrylic Resin Binder
- Rated Velocity
11-1/2" Depth - 500 FPM
5-7/8" Depth - 250 FPM
- See Drawings MKT-B-00359 For Resistance Curves
- Recommended Final Resistance: 2.0" W.G. @ Rated Flow (Twice Initial Resistance)
- Class 2 Filter Per U.L. Standard 900
- Maximum Operating Temperature: 180 Deg. F
- Standard Gasket Location Downstream, Construction Code 000 000 000
- Optional Gasket Locations (Do NOT Use Item Numbers Shown Above)
-U: Upstream Side (Ex. MDL-501-U), Construction Code 000 110 000
-UD: Both Sides (Ex. MDL-501-UD), Construction Code 000 130 000
No Gasket (Ex. MDL-501, No Gasket), Construction Code 000 750 000

ONE SOURCE
FOR
AIR FILTRATION
PRODUCTS

P.O. Box 32578
Louisville, KY 40232
P: 502-969-2304
F: 502-969-2759

CONTACT FACTORY TO
VERIFY REVISION LEVEL

**TOLERANCES
UNLESS OTHERWISE SPECIFIED**

FRACTIONAL	-
DECIMAL	-
ANGLES	-

ALL DIMENSIONS IN INCHES

DRAWING NAME
MICROGUARD 95
(PARTICLE BOARD BOX - 95% DOP)

APPROVED BY <i>H. Quinn</i>	SPECIFICATION NO. MKT-B-00381	PAGE 1 OF 1
SCALE NONE	DWG. SIZE A	REVISION A
		REVISION DATE 12-09-04

CONFIDENTIAL - DO NOT COPY. THIS MATERIAL IS TRADE SECRET AND PROPRIETARY BEING EXCLUSIVELY OWNED BY AIRGUARD. THE EXPRESSION OF THE INFORMATION CONTAINED HEREIN IS PROTECTED UNDER FEDERAL COPYRIGHT LAWS AND ALL COPYING IS PROHIBITED AND MAY BE SUBJECT TO CRIMINAL PENALTIES.