

Item Number	Model Number	Construction Code	Actual Size (Inches) H x W x D	Rated Air Flow (CFM)	Initial Resistance (In. W.G.)	Efficiency	Media Area (Square Feet)
2954466	MDL-501-ML	M2424B00-0EG 000 000	24 x 24 x 11-1/2	2000	1.00	95% @ 0.3 Micron	202
2954647	MDL-501A-ML	M2323B33-0EG 000 000	23-3/8 x 23-3/8 x 11-1/2	1900	1.00	95% @ 0.3 Micron	189
2954994	MDL-500-ML	M1224B00-0EG 000 000	12 x 24 x 11-1/2	1000	1.00	95% @ 0.3 Micron	94
	MDL-500A-ML	M1123B33-0EG 000 000	11-3/8 x 23-3/8 x 11-1/2	950	1.00	95% @ 0.3 Micron	85
2954467	MDL-500R-ML	M2412B00-0EG 000 000	24 x 12 x 11-1/2	1000	1.00	95% @ 0.3 Micron	94
2955203	MDL-500AR-ML	M2311B33-0EG 000 000	23-3/8 x 11-3/8 x 11-1/2	950	1.00	95% @ 0.3 Micron	85
2954757	MDL-241-ML	M2424A00-0EG 000 000	24 x 24 x 5-7/8	1000	1.00	95% @ 0.3 Micron	105
2954460	MDL-241A-ML	M2323A33-0EG 000 000	23-3/8 x 23-3/8 x 5-7/8	950	1.00	95% @ 0.3 Micron	99
2951508	MDL-1202-ML	M1224A00-0EG 000 000	12 x 24 x 5-7/8	500	1.00	95% @ 0.3 Micron	49
	MDL-1202A-ML	M1123A33-0EG 000 000	11-3/8 x 23-3/8 x 5-7/8	475	1.00	95% @ 0.3 Micron	44
2958878	MDL-1212-ML	M2412A00-0EG 000 000	24 x 12 x 5-7/8	500	1.00	95% @ 0.3 Micron	49
2954770	MC-1212A-ML	M2311A33-0EG 000 000	23-3/8 x 11-3/8 x 5-7/8	475	1.00	95% @ 0.3 Micron	44

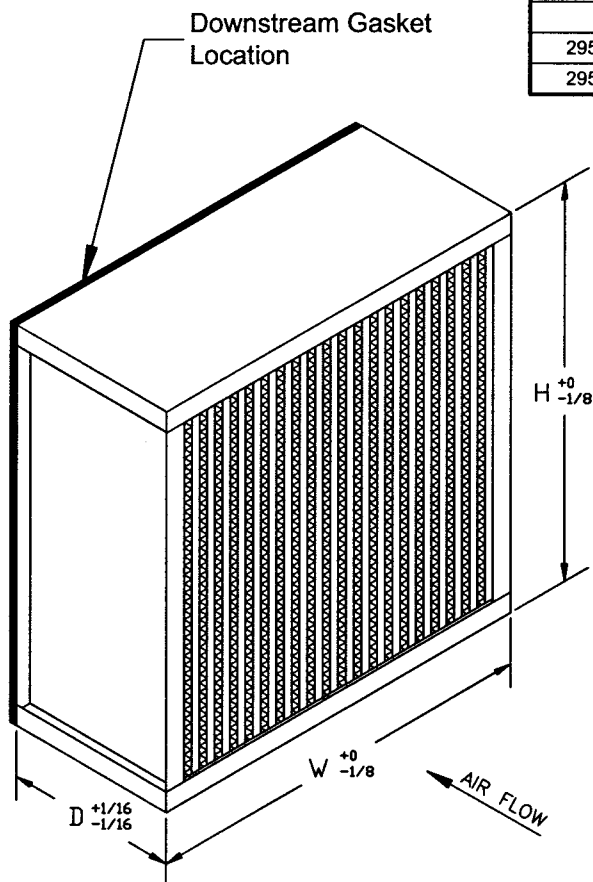

Construction	Code	Description
Standard and Certification	0	HEPA-TEST-RP-CC001.3 per MIL Std. 282
Frame Material	E	24 GA Corrosion Resistant Steel
Frame Style	G	Metal C-Style
Gasket	0	Urethane 1/4" x 3/4" (180 deg. F), Dovetail Joints
Gasket Location	0	Downstream
Sealant	0	Urethane (180 deg. F)
Hardware	0	None
Acceptance Level	0	95% on 0.3 Micron
Separators	0	Aluminum Separators, Standard Capacity

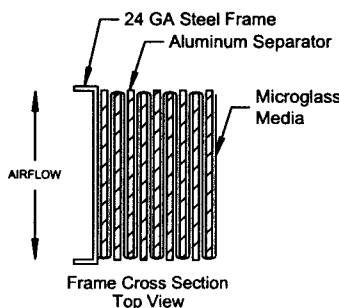

**NOTES**

- Media: Micro-Glass Fiber / Acrylic Resin Binder
- Rated Velocity  
11-1/2" Depth - 500 FPM  
5-7/8" Depth - 250 FPM
- See Drawings MKT-B-00359 For Resistance Curves
- Recommended Final Resistance: Twice Initial Resistance  
(Ex. MDL-501-ML Final Resistance: 2.0" W.G. @ 2000 CFM)
- Class 1 Filter Per U.L Standard 900
- Maximum Operating Temperature: 180 Deg. F
- Standard Gasket Location Downstream, Construction Code 0EG 000 000
- Optional Gasket Locations (Do NOT Use Item Numbers Shown Above)  
-U: Upstream Sides (Ex. MDL-501-ML-U), Construction Code 0EG 110 000  
-UD: Both Sides (Ex. MDL-501-ML-UD), Construction Code 0EG 130 000  
No Gasket (Ex. MDL-501-ML, No Gasket), Construction Code 0EG 750 000

**AIRGUARD** ONE SOURCE FOR AIR FILTRATION PRODUCTS  
 P.O. Box 32578  
 Louisville, KY 40232  
 P: 502-969-2304  
 F: 502-969-2759

**CONTACT FACTORY TO VERIFY REVISION LEVEL**

**TOLERANCES UNLESS OTHERWISE SPECIFIED**

FRACTIONAL	-
DECIMAL	-
ANGLES	-

ALL DIMENSIONS IN INCHES

DRAWING NAME: **MICROGUARD 95 (24 GA C STYLE BOX - 95% DOP)**

APPROVED BY: <i>KCO</i>	SPECIFICATION NO. MKT-B-00382	PAGE 1 OF 1
SCALE: NONE	DWG. SIZE: A	REVISION: A
		REVISION DATE: 12-09-04

CONFIDENTIAL - DO NOT COPY. THIS MATERIAL IS TRADE SECRET AND PROPRIETARY BEING EXCLUSIVELY OWNED BY AIRGUARD. THE EXPRESSION OF THE INFORMATION CONTAINED HEREIN IS PROTECTED UNDER FEDERAL COPYRIGHT LAWS AND ALL COPYING IS PROHIBITED AND MAY BE SUBJECT TO CRIMINAL PENALTIES.